

# T4

Codice testa  
Head code

Codice mandrino  
Spindle code

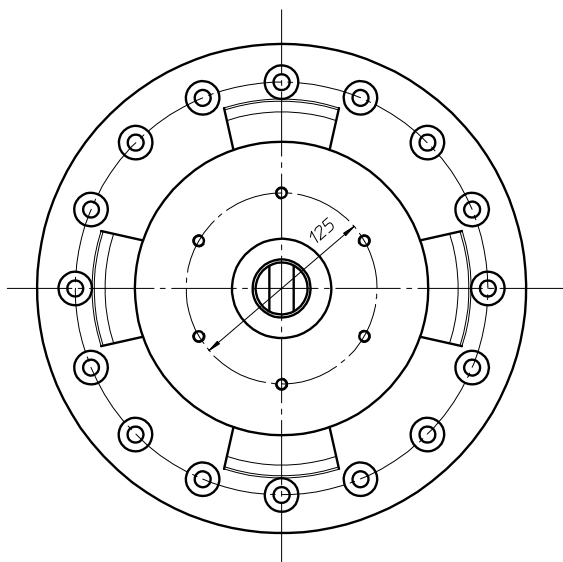
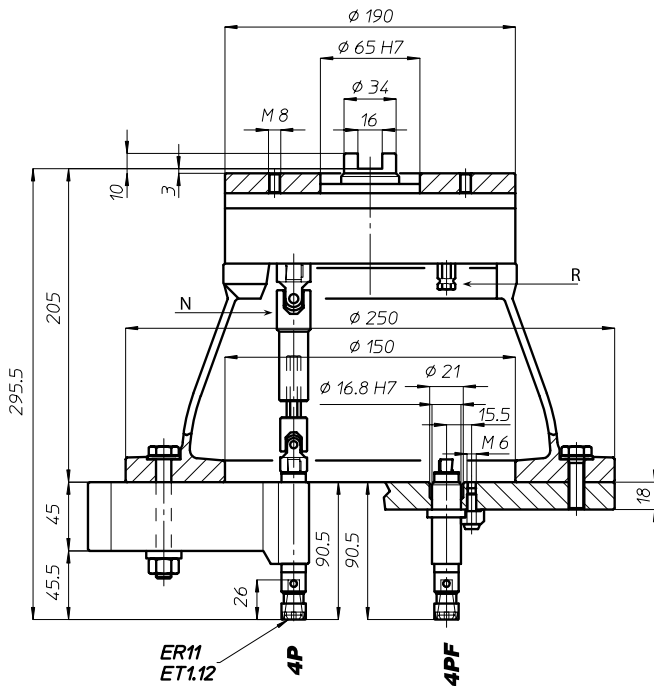
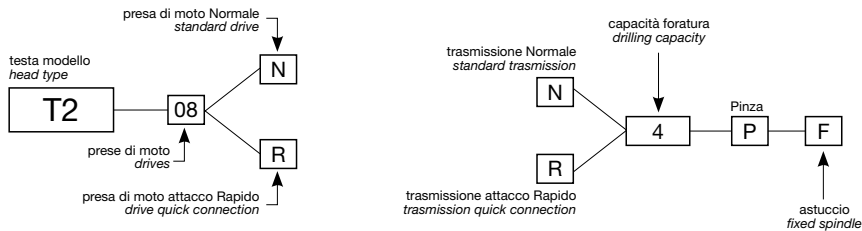

N° prese di moto  
Nr. spindle drives

08-12



Rapporto  
Ratio

1-1



Capacità di foratura  
Drilling capacity  
acciaio R=500 N/mm<sup>2</sup>  
ghisa: GG25

4

5



Maschiatura  
Tapping

M4



Attacco utensile  
Type of spindle  
P

ER11



Peso gruppo testa  
Head weight

Kg 9,5



Peso gruppo mandrino  
Spindle-set weight

Kg 1

area di lavoro  
working area

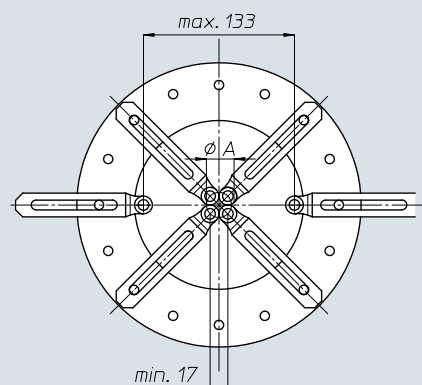

$\phi A$	n° mandrini n° spindles
20	3
24,5	4
29,5	5
34,5	6
39,5	7
45	8



BAH

TA.CP

TA

MO

HT

VH

TSI/TSX

T

MT-T-C3

Accessori  
Accessories

Appendice tecnica  
Technical supplement

8-3